

A pressure sensor, digital VAV controller and damper actuator all in one, providing a compact solution with a communications capability for pressure-independent VAV and CAV systems in the comfort zone

- Control (0)2...10 V or via MP-Bus
- MP-Bus: Control device with MP interface, Gateway: BACnet / LON / Modbus / KNX
- Conversion of sensor signals
- Service socket for operating devices
- NFC interface for smartphone App



LMV-D3-MP



NMV-D3-MP

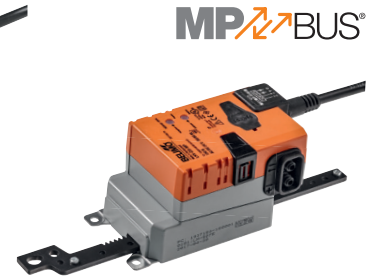

LHV-D3-MP



Belimo Assistant App

Product Features

Application	The VAV-Compact has PI control characteristics and is used for pressure-independent control of VAV units in the comfort zone.
Pressure measurement	The integrated D3 differential pressure sensor is also suitable for very small volumetric flows. The maintenance-free sensor technology enables versatile applications in the comfort zone: in residential construction, offices, hospitals, hotels, cruise ships, etc..
Actuator	VAV unit manufacturers offer different actuator variants (rotary or linear actuator) for different VAV units structures.
Control function	Volumetric flow (VAV-CAV) or Open-Loop (for integration in an external VAV control loop).
VAV – variable volumetric flow	Demand-dependent setting of volumetric flows $\dot{V}_{min} \dots \dot{V}_{max}$ on a modulating reference variable (0/2...10 V / MP-Bus), e.g. room temperature / CO2 levels, DDC or Bus system, for energy-saving air conditioning in individual rooms or zones.
CAV – constant volumetric flow	Step mode (via switching contact) for constant volume applications CLOSED / \dot{V}_{min} / \dot{V}_{max} / OPEN.
DCV – Demand Controlled Ventilation	Can be used in conjunction with third party controller or BMS in demand controlled ventilation applications.
Bus operation	Belimo MP devices (VAV / damper and valve actuators) can be connected to a MP master device via the MP-Bus: <ul style="list-style-type: none"> – MP partner solution: DDC controller with integrated MP-Bus protocol – Gateway for the integration in BACnet and Modbus applications In Bus operation an additional sensor (0...10 V / passive) such as temperature or a switch for the higher-level system can be integrated. See separate MP-Bus documentation at www.belimo.us .
Operating and service devices	Smartphone Assistant App: Contactless operating via the integrated NFC interface*. Service tool ZTH, PC-Tool service socket: locally pluggable or via MP-Bus.

Electrical connection The connection is made with the integrated connection cable.

Type overview MP versions	Type	Torque	Power consumption	Rating	Weight
	LMV-D3-MP	45 in-lb [5 Nm]	2 W	3.5 VA	Approx. 1.1 lb [500 g]
	NMV-D3-MP	90 in-lb [10 Nm]	3 W	5 VA	Approx. 1.5 lb [700 g]
	LHV-D3-MP	34 lbf [150 N]	2.5 W	4.5 VA	Approx. 1.2 lb [550 g]

OEM version In addition to the standard Belimo version, there are OEM VAV-Compact versions available for VAV unit manufacturers' variants. These versions are customized and labelled specifically for OEM on the sensors, damper spindles and fastening systems used. See documentation of the VAV unit manufacturer.
Designation, e.g.: LMV-D3-MP ABC (ABC = Customer designation)

Other versions The VAV-Compact is also available with a built-in interface for direct integration in BACnet and Modbus. MFT version also available. See www.belimo.us for more information and documentation.

* Android devices only. Zip-BT-NFC required for iPhone devices.

Safety notes



- The device must not be used outside the specified field of application, especially not in aircraft or in any other airborne means of transport.
- Outdoor applications: possible only in the absence of direct effects on the actuator from (sea) water, snow, ice, sunlight and aggressive gases and when it is guaranteed that the ambient conditions do not deviate at any time from the limit values specified in the datasheet.
- Only authorized specialists may carry out installation. All applicable legal or institutional installation regulations must be complied with during installation.
- The device may only be opened at the manufacturer's site. It does not contain any parts that can be replaced or repaired by the user.
- Cables must not be removed from the device.
- When calculating the torque required, the specifications supplied by the damper manufacturers (cross-section, construction, place of installation), and the ventilation conditions must be observed.
- The device contains electrical and electronic components and is not allowed to be disposed of as household refuse. All locally valid regulations and requirements must be observed.

Electrical installation

Notes

- Supply via safety isolating transformer!
- In conventionally controlled systems it is recommended that the connections 1 to 5 (PP) are led to accessible terminals (e.g. floor distributor) in order to allow remote access for diagnostics and service work.

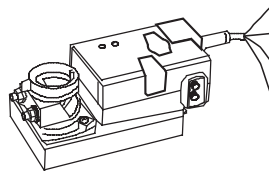

No.	Designation	Wire color	Function
1	⊥ -	black	} AC/DC 24 V supply
2	~ +	red	
3	◀ Y	white	Reference signal / override / sensor
5	▶ U	orange	- Actual value signal - MP bus connection

See separate documentation for description of functions and applications

Technical Data			
Electrical data	Nominal voltage	AC/DC 24 V, 50/60 Hz	
	Operating range	AC 19.2 ... 28.8V / DC 21.6 ... 28.8V	
	Performance data	See Overview of types (page 1)	
	Connecting	3 ft [1 m] 18 GA plenum rated cable, [4 x 0.75 mm ²], preassembled	
Volumetric flow controllers	Control function	VAV/CAV and Open-Loop	
	\dot{V}_{nom} ¹⁾	Application specific nominal volumetric flow setting, dependent upon VAV box parameters. Used for calibration.	
	$\Delta p @ \dot{V}_{nom}$ ¹⁾	Change in pressure at nominal volumetric flow setting, dependent upon VAV box parameters. Used for calibration.	
	\dot{V}_{max}	20 ... 100 % of \dot{V}_{nom} , adjustable Max flow required in application	
	\dot{V}_{min}	0 ... 100 % of \dot{V}_{nom} , adjustable (< \dot{V}_{max})	
Analogue control - VAV	Mode (Y)	0 ... 10 V / 2 ... 10 V / (Y and U5 individually) adjustable, input resistance 100k Ω (0/4...20 mA with 500 Ω resistance)	
	Actual value signal (U)	0 ... 10 V / 2 ... 10 V, max. 0.5 mA Volumetric flow / damper position / Δp , selectable	
Stepped control - CAV	Operating stages	CLOSED / \dot{V}_{min} / \dot{V}_{max} / OPEN	
Bus mode	Communication	Belimo MP bus	
	Addressing	MP1 ... 8 (analog control: PP)	
	Bus master	DDC with MP interface (see Belimo MP Partners List www.belimo.eu)	
	Control	The setpoint specification in % between the set \dot{V}_{min} / \dot{V}_{max} values	
	Sensor integration	Passive sensor (PT1000, 10K2, ..) or active sensor (0...10 V) Switching contact (0 / 1) (switching capacity 16 mA @ 24 V)	
Operation and servicing	Assistant App (Smartphone)	Contactless connection via the integrated NFC interface	
	Service tool ZTH, PC-Tool	Local plug / Remote via PP/MP connection or MP master	
	LED	Supply, status and communication display	
	Push-button	Addressing, angle of rotation adaptation and test function	
Actuator	Rotary/linear version	Brushless, non-blocking actuator with power-save mode	
	Direction of rotation	left / right or up / down, adjustable	
	Angle of rotation	95° or 4 [100] / 8 [200] / 12 [300] in [mm] stroke, adjustable mechanical or electronic limiting	
	Gear disengagement	Push-button self-resetting without functional impairment	
	Position indication	Mechanical or accessible (Tool, Bus-Master)	
	Spindle holder	Spindle clamp for round and square shafts form fit, OEM versions	
Volumetric flow measurement	Differential pressure sensor	Belimo D3 sensor, dynamic measurement principle	
	Measurement range, operating range	-0.08...2 in WC [-20...500 Pa], 0...2 in WC [0...500 Pa]	
	Overload capability	± 12 in WC [± 3000 Pa]	
	Altitude compensation	Adaptation to system altitude (adjustable between 0...9800 ft. [0...3000 m] above sea level)	
	Installation position	Any, no reset necessary	
	Materials in contact with medium	Glass, epoxy resin, PA, TPE	
	Measuring air conditions	Comfort zone 32...122°F [0...50°C] / 5...95% rH, non-condensing	
Safety	Protection class IEC/EN	III Safety extra-low voltage	
	Degree of protection IEC / EN	IP54	
	EMC	CE according to 2014/30/EU	
	Certification IEC/EN	IEC/EN 60730-1 and IEC/EN 60730-2-14	
	Rated current voltage	0.8 kV	
	Supply / control		
	Control pollution degree	3	
	Ambient temperature	-22...+122°F [-30...50°C]	
	Non-operating temperature	-40...+176°F [-40...80°C]	
	Ambient humidity range	95% r.h., non-condensing	
	Maintenance	Maintenance-free. Depending on the application, the differential pressure sensor (measuring cross, disc, ..) of the VAV unit is checked occasionally and cleaned if required.	
	UL listing	cULus according to UL 60730-1A/-2-14, UL 2043	

¹⁾ Set during calibration. Dependent upon VAV box parameters.

FCC: see US-relevant notes on page 12

VAV – variable operation $\dot{V}_{min} \dots \dot{V}_{max}$

Wiring diagrams

Example 1:
VAV, analogue reference signal

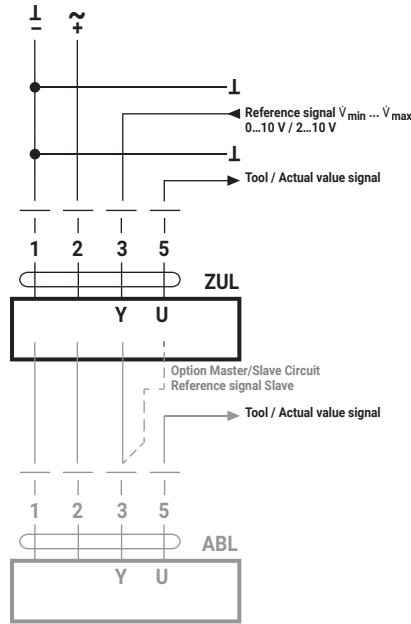

Example 2:
VAV with shut-off (CLOSED), 2...10 V mode

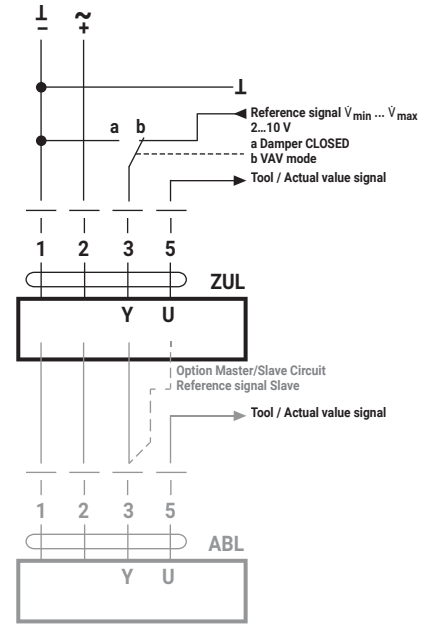

Description:

Damper CLOSED via 0...10 V reference signal (Mode 2...10 V)

Setting parameters:

Mode 2...10 V, Shut off level 0.1 V or 0.5 V

If the required switching threshold of 0.1 V cannot be attained, the value can be switched to 0.5 V with PC-Tool.

Function: Standard 0.1 V: Shut-off level 0.5 V:

Damper		
CLOSED	<0.1 V	<0.5 V
\dot{V}_{min}	>0.1...2 V	>0.5 V...2 V
$\dot{V}_{min} \dots \dot{V}_{max}$	2...10 V	2...10 V

In CAV applications shut-off level must not be set to 0.5 V, otherwise the open connection 3 is interpreted as damper CLOSED.

CAV – step mode CLOSED / \dot{V}_{min} / \dot{V}_{max} / OPEN

CAV control

VAV-Compact can be adapted to the desired CAV function pattern for constant volumetric flow applications with PC-Tool by using the "CAV function":
– Damper CLOSED – \dot{V}_{min} – \dot{V}_{max} – damper OPEN (standard)

Wiring diagrams

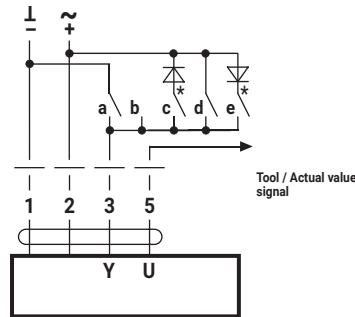

Notes

- Note that the contacts are mutually interlocking.
- DC supply: * c and e are not available with DC 24 V.
- Setting parameters in CAV applications: Mode 2...10 V, Shut-off level 0.1 V
- In CAV applications shut-off level must not be set to 0.5 V, otherwise the open connection 3 is interpreted as damper CLOSED.

PC-Tool "CAV Function" setting:
2 ... 10 V, Shut-off level 0.1 V

CAV Function CLOSED – \dot{V}_{min} – \dot{V}_{max} – OPEN (standard)

	a	b	c	d	e
Signal	⊥		~	~	~
	-			+	
Switching terminal 3			⊥		⊥
Mode 2 ... 10 V	CLOSED	\dot{V}_{min}	CLOSED *	\dot{V}_{max}	OPEN *
Mode 0 ... 10 V	\dot{V}_{min}	\dot{V}_{min}	CLOSED *	\dot{V}_{max}	OPEN *

PC-Tool "CAV Function" setting:
CLOSED – \dot{V}_{min} – \dot{V}_{max} . Shut-off level CLOSED: 0.1 V

MP-Bus operation – VAV / CAV function

Connection on the MP-Bus

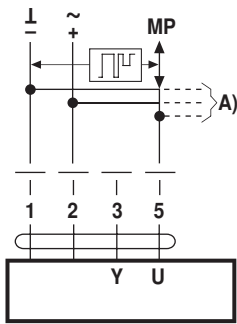

A) Additional actuators and sensors (max. 8)

Power topology

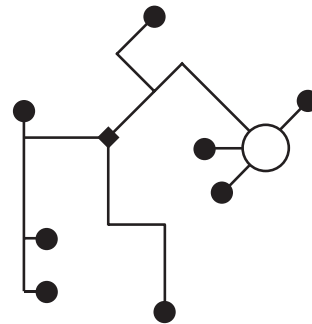

There are no restrictions for the network topology (star, ring, tree or mixed forms are permitted).
Supply and communication in one and the same 3-wire cable

- no shielding or twisting necessary
- no terminating resistors required

Connection of active sensors

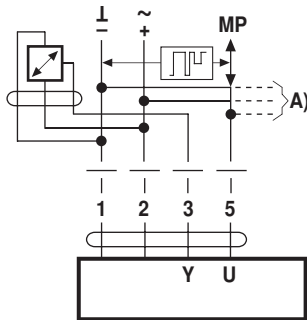

A) Additional actuators and sensors (max. 8)

- Supply AC / DC 24 V
- Output signal DC 0...10 V (max. DC 0...32 V)
- Resolution 30 mV

Connection of external switching contact

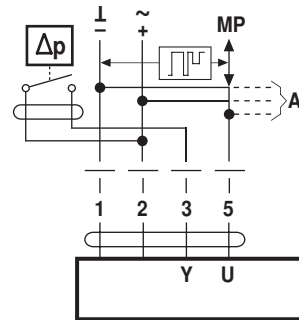

A) Additional actuators and sensors (max. 8)

- Switching current 16 mA @ 24 V
- Start point of the operating range must be parameterized on the MP actuator as ≥ 0.5 V

Connection of passive sensors

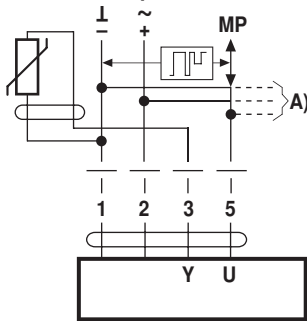

Sensor Type	Operating Temperature Range	Belimo Part (e.g.)
NTC (10K2)	-60...+300°F [-50...+150°C]	01CT-5Lx 01DT-5Lx
Ni1000	-60...+320°F [-50...+160°C]	01CT-5Ex 01DT-5Ex
PT1000	-60...+320°F [-50...+160°C]	01CT-5Bx 01DT-5Bx

A) Additional actuators and sensors (max. 8)

Local override control

If no sensor is integrated, then connection 3 (Y) is available for the protective circuit of a local override control.

Options: CLOSED – \dot{V}_{max} – OPEN

Note: Functions only with AC 24 V supply!

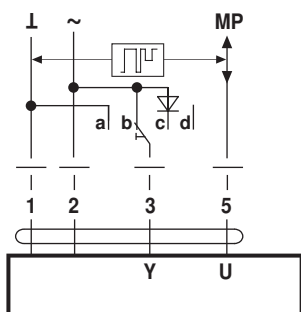

a Damper CLOSED
b \dot{V}_{Max}
c Damper OPEN
d Bus mode

See www.belimo.us / Bus and System Integration for detailed information on MP-Bus and installation (max. signal cable lengths, etc.)

Control functions - VAV / CAV

VAV-operating volumetric flow – Setting and control

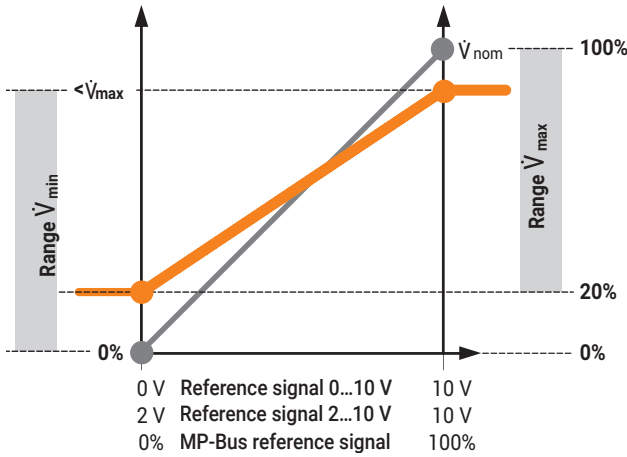

Damper CLOSED via 0...10 V reference signal (Mode 2...10 V)

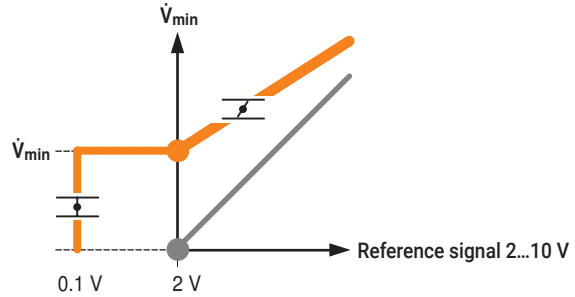

Description:

Setting parameters: Mode 2...10 V, Shut-off level 0.1 V or 0.5 V

If the required switching threshold of 0.1 V cannot be attained, the value can be switched to 0.5 V with PC-Tool.

Function	Standard 0.1 V	Shut-off level 0.5 V
Damper CLOSED	<0.1 V	<0.5 V
\dot{V}_{min}	>0.1...2 V	>0.5 V...2 V
$\dot{V}_{min} \dots \dot{V}_{max}$	2...10 V	2...10 V

In CAV applications shut-off level must not be set to 0.5 V, otherwise the open connection 3 is interpreted as damper CLOSED.

VAV-operating volumetric flow - Example

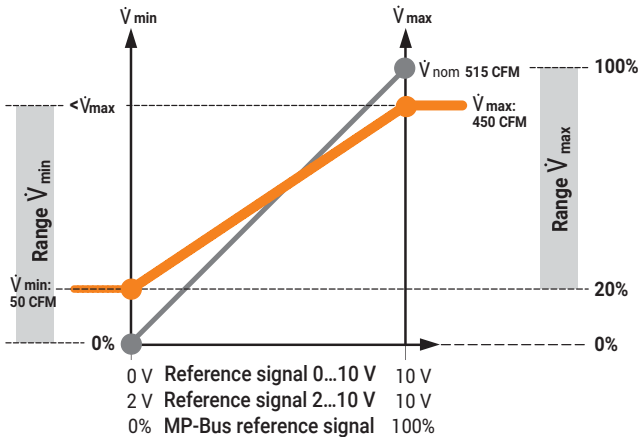

\dot{V}_{nom} - Volumetric flow rate used for calibration
 \dot{V}_{max} - Max desired volumetric flow rate
 \dot{V}_{min} - Minimum desired volumetric flow rate

Open-Loop (separate external VAV-Control)

Control damper Y

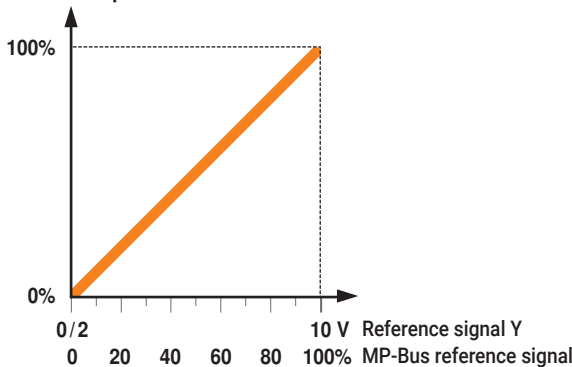

CAV operating volumetric flow – setting

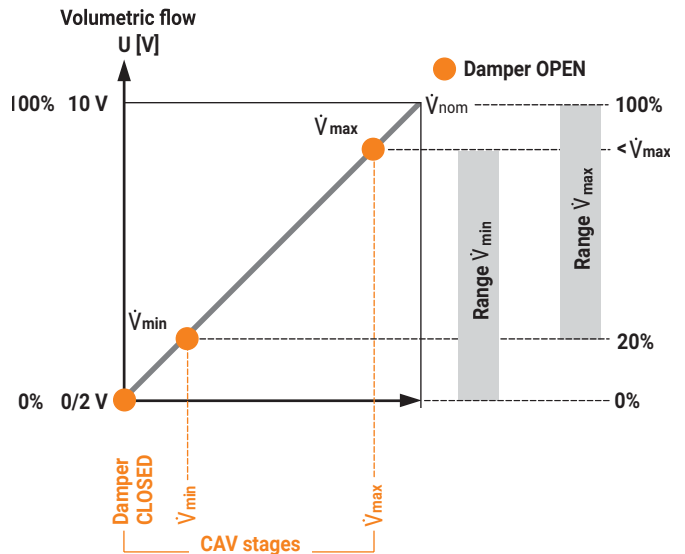

Volumetric flow sensor value

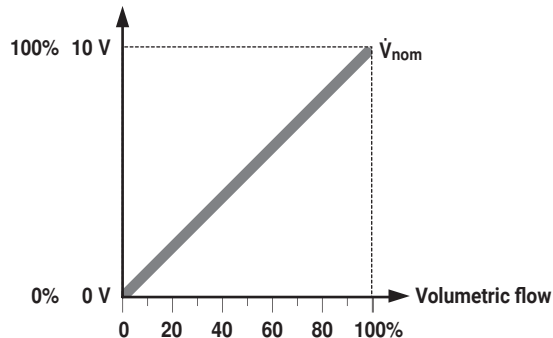

Setting and Tool function

Designation	Adjustment values, limits, explanations	Units	Tools ⁵⁾			Remarks
			Assistant App ⁶⁾	ZTH US	PC-Tool	
System specific data						
Position	16 characters e.g.: Office 4 6.0G ZL	Text	r/w	r	r/w	
Designation	16 Characters: Unit designation, etc.	Text	r	r	r/w	
Address	PP / MP1...8		r/w ¹⁾	r/w	r/w	PP: 0...10 / 2...10 V MP1...8: MP mode
\dot{V}_{max}	20...100% [\dot{V}_{nom}]	m ³ /h / l/s / cfm	r/w	r/w	r/w	>= \dot{V}_{min}
\dot{V}_{mid}	\dot{V}_{min} ... \dot{V}_{max}	m ³ /h / l/s / cfm	r/w	r/w	r/w	
\dot{V}_{min}	0...100% [\dot{V}_{nom}]	m ³ /h / l/s / cfm	r/w	r/w	r/w	<= \dot{V}_{max}
System altitude	0...3000 0...9800	Meter Feet	-	r/w	r/w	Adaptation Δp -Sensor to system altitude (above sea level)
Controller settings						
Controller function	Volumetric flow / open loop		r/w	-	r/w	
Mode	0...10 / 2...10	Volt	r/w ¹⁾	r/w ¹⁾	r/w	
CAV function	CLOSED/ \dot{V}_{min} / \dot{V}_{max} ; Shut-off level CLOSED 0.1 V CLOSED/ \dot{V}_{min} / \dot{V}_{max} ; Shut-off level CLOSED 0.5 V		-	-	r/w	For an explanation see ²⁾
Positioning signal Y	Start value: 0.6...30; Stop value: 2.6...32	Volt	r	r	r/w	
Feedback U	Volume / damper position / Δp		r/w**	-	r/w	Definition feedback signal ** Device must be powered
Feedback U	Start value: 0.0...8.0; Stop value: 2.0...10	Volt	-	-	r/w	
Response when switched on (Power-On) ⁴⁾	No action / Adaption / Synchronization		-	-	r/w	
Synchronization behavior	Y=0 % Y=100 %		-	-	r/w	Synchronization to damper position 0 or 100 %
Bus fail position	Last set point / Damper CLOSED \dot{V}_{min} / \dot{V}_{max} / Damper OPEN		-	-	r/w	
Unit specific settings *) Write function only available in expert mode						
\dot{V}_{nom}	0...35,000 cfm / 0...60,000 m ³ /h	m ³ /h / l/s / cfm	r	r	r/(w*)	Unit specific adjustment value
$\Delta p@ \dot{V}_{nom}$	0.15...2 in WC [38 ... 500 Pa]	in WC [Pa]	-	r	r/(w*)	Unit specific adjustment value
NFC interface	read / read&write		r	-	r/(w*)	
Label print function			-	-	w	Incl. customer logo
Other settings						
Direction of rotation (for Y = 100%)	cw/ccw or $\blacktriangle/\blacktriangledown$		r/w ¹⁾	r/w ¹⁾	r/w	
Range of rotation	Adapted ³⁾ / programmed 30...95	°	-	-	r/w	
Torque	100 / 75 / 50 / 25	%			r/w	% of nominal torque
Renovating Existing systems (Retrofit of old VAV units with leaking damper *) Parameters are only accessible by VAV manufacturers and Retrofit Partners)						
Suppress damper leak	Yes/No		-	-	r/(w*)	Suppresses volume display with the damper closed
Operating data						
Setpoint / actual value		m ³ /h / l/s / cfm	r	r	r	Trend display with print function and data storage on HD
Damper position		Pa / %				
Simulation	Damper CLOSED / OPEN \dot{V}_{min} / \dot{V}_{max} / motor stop		-	w	w	
Running times	Operating time, running time Ratio	h %	-	-	r	
Alarm messages	Setting range enlarged, mech. overload, Stop&Go ratio too high		-	-	r/w	
Series number	Device ID.		r	r	r	incl. date of manufacture
Type	Type designation		r	r	r	
Version display	Firmware, Config table ID		-	r	r	
Configuration data						
Print, create PDF			-	-	Yes	
Save to file			-	-	Yes	
Log data / book	Activity log		-	-	Yes	incl. complete setting data

Explanations

- 1) Access only on operating level 2
- 2) Shut-off level 0.1 / 0.5V - Application: VAV mode, in Mode 2...10 V, Damper CLOSED via 0...10 V control signal.
If the required switching threshold of 0.1 V cannot be attained, the threshold can be switched to 0.5 V.
Note on CAV application: the shut-off level must not be set to 0.5 V. If the line 3 (Y) is open, damper will be CLOSED instead, min will be activated.
- 3) Within the mechanical limit.
- 4) The first time the supply voltage is switched on, i.e. at the time of commissioning, the actuator carries out an adaption, which is when the operating range and position feedback adjust themselves to the mechanical setting range. The actuator then moves into the required position in order to ensure the volumetric flow defined by the positioning signal.
- 5) See www.belimo.us for function and version history.
- 6) iPhone devices require use of ZIP-BT-NFC

Display and operation

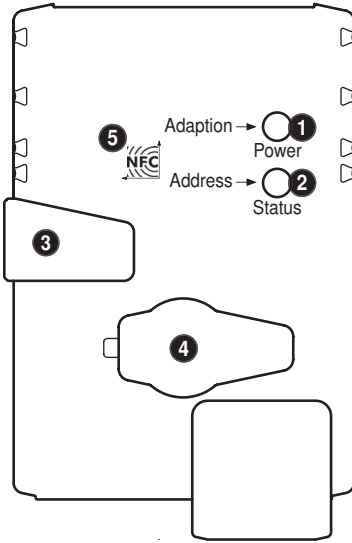

- 1 Push-button and LED display green**
Off: No power supply or fault
On: Operation
Press key: Triggering the angle of rotation adaptation
- 2 Push-button and LED display yellow**
Off: Normal operation
Flickering: MP communication active
On: Adaptation or synchronizing process active
Flashing: Addressing request sent to MP master
Press key: Confirmation of the addressing
- 3 Gear disengagement key**
Press key: Gear disengaged, motor stops, manual override possible
Release key: Gear engaged, synchronization starts, followed by standard operation
- 4 Service plug** For connecting the parameterization and service tools
- 5 NFC Logo** operated with Belimo Assistant App

MP-Bus mode: display panel wiring

- 1** Off and **2** On AC supply: connection 1 (L) and 2 (~) reversed
- 1** Off and **2** Off DC supply: connection 1 (-) and 2 (+) reversed

The test is performed once to switch on the 24 V supply.
For this test, the MP master must be connected to VAV-Compact.

NFC, Smartphone – Assistant App



Devices marked with NFC-Logo can be operated contactless via the NFC interface with Assistant App (..MV-D3-MP as of MY 2015).

Prerequisites:

- NFC-enabled Android smartphone
- Belimo Assistant App (Google Play Store)

The optimum tuning range is located within the antenna range indicated by the arrows.
Align smartphone on the VAV-Compact so that both NFC antennas are superimposed.

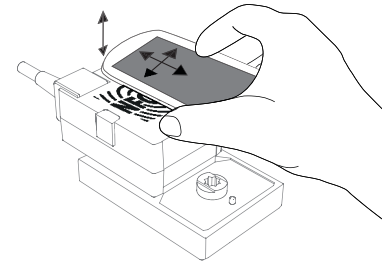

ZTH / PC-Tool - local service connection

The settings and diagnostics of the VAV-Compact can be performed easily and rapidly with the Belimo PC-Tool or with the ZTH-US service tool. When using the PC-Tool, the ZTH US serves as an interface converter.

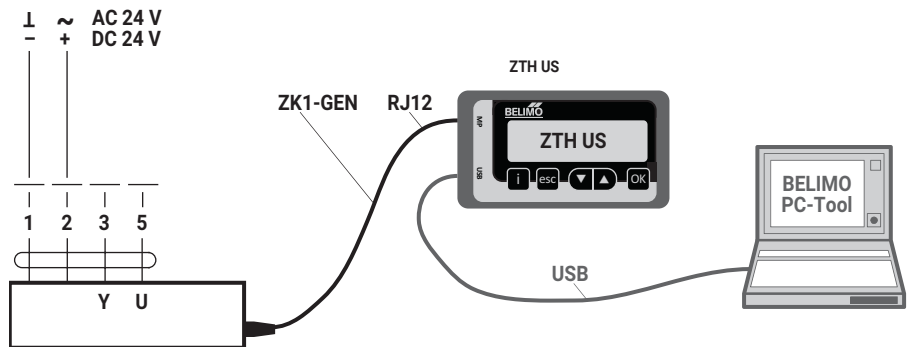

Download PC-Tool (MFT-P) from www.belimo.us

Display and operation

ZTH / PC-Tool - remote connection

The VAV-Compact can communicate with the service tools via the MP connection (wire 5). The connection can be made in operating mode in the junction box, tool socket of room controllers CR 24 or the control cabinet terminals. In MP-Bus mode, the tool is connected to MP master. When using the PC-Tool, the ZTH US serves as an interface converter.

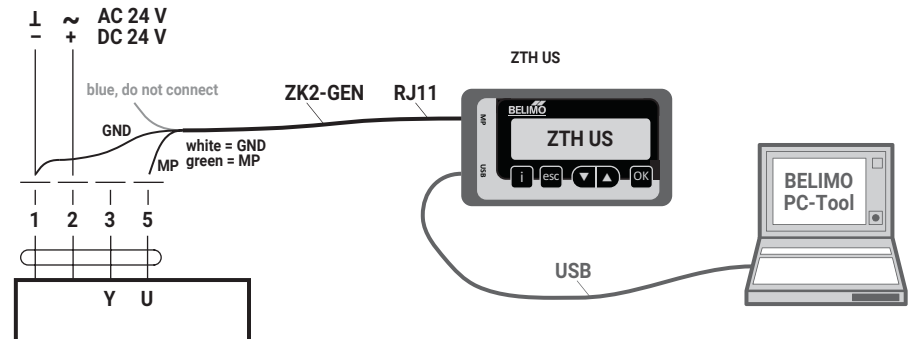

Accessories

Gateways	Description	Type
	Gateway MP to BACnet MS/TP, AC/DC 24 V	UK24BAC
	Gateway MP to Modbus RTU, AC/DC 24 V	UK24MOD
	Gateway MP to KNX/EIB, AC/DC 24 V, EIBA certified	UK24EIB
	Gateway MP to LONWORKS®, AC/DC 24 V, LONMARK certified	UK24LON
VAV-Compact	Description	
	VAV-Compact: Version with integrated BACnet and Modbus see www.belimo.us for more information and documentation	
Electrical accessories	Description	Type
	Connection cable 16 ft [5 m], to ZTH (RJ12) with service plug	ZK1-GEN
	Connection cable 16 ft [5 m], to ZTH (RJ11) with free wire ends	ZK2-GEN
Tools	Description	Type
	Service Tool, for MFT/MP/BACnet/Modbus actuators and VAV controllers	ZTH US
	Belimo PC-Tool, software for adjustments and diagnostics (Free download at www.belimo.us)	
	Belimo Assistant App, for Android smartphone	

Dimensions inches [mm]

Dimensional drawings LMV-D3-MP

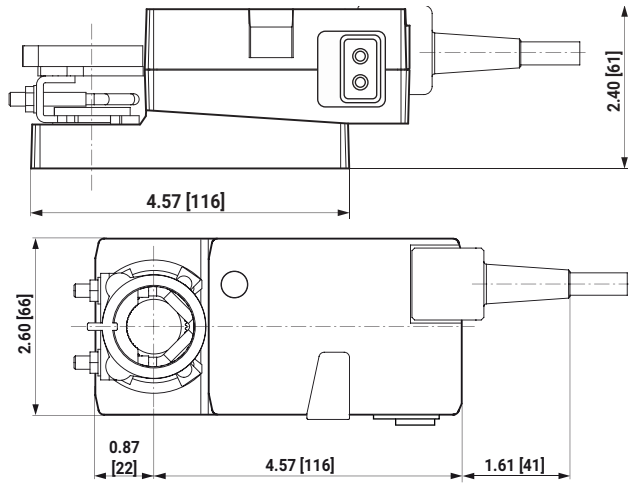

Dimensional drawings NMV-D3-MP

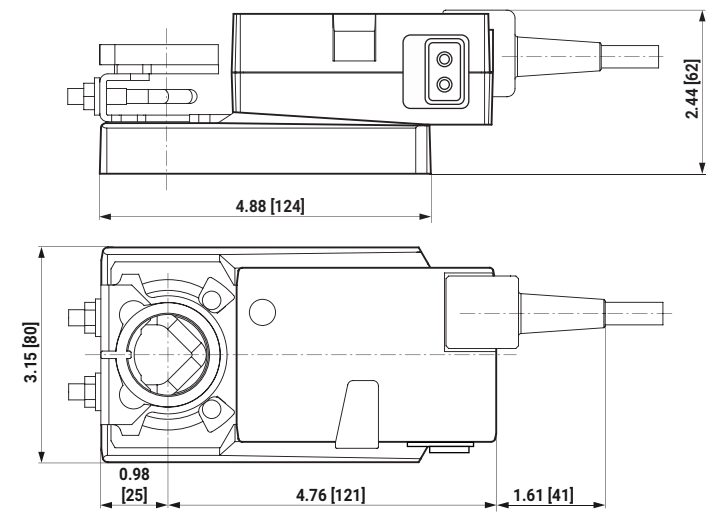

Dimensional drawings LHV-D3-MP

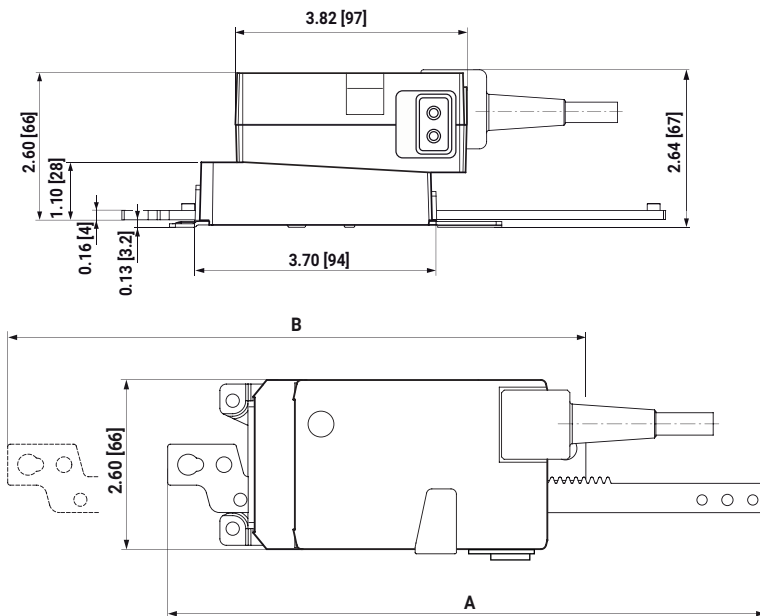

Type	Max. stroke	A	B
LHV-D3-MP-100	4" [100 mm]	9.19 [233.5]	10.40 [264.2]
LHV-D3-MP-200	8" [200 mm]	13.13 [333.5]	14.34 [364.2]
LHV-D3-MP-300	12" [300 mm]	17.07 [433.5]	18.28 [464.2]

FCC notes (relevant only for US market)

This device complies with part 15 of the FCC:

Operation is subject to the following two conditions:

1. This device may not cause harmful interference, and
2. this device must accept any interference received, including interference that may cause undesired operation.

The following statement applies to the products covered in this manual, unless otherwise specified herein. The statement for other products will appear in the accompanying documentation.

NOTE:

This equipment has been tested and found to comply with the limits for a Class B digital device, pursuant to part 15 of the FCC Rules. These limits are designed to provide reasonable protection against harmful interference in a residential installation. This equipment generates, uses and can radiate radio frequency energy and, if not installed and used in accordance with the instructions, may cause harmful interference to radio communications. However, there is no guarantee that interference will not occur in a particular installation.

If this equipment does cause harmful interference to radio or television reception, which can be determined by turning the equipment off and on, the user is encouraged to try to correct the interference by one or more of the following measures:

- Reorient or relocate the receiving antenna.
- Increase the separation between the equipment and receiver.
- Connect the equipment into an outlet on a circuit different from that to which the receiver is connected.
- Consult the dealer or an experienced radio / T.V. technician for help.

Further documentation

- Overview of MP co-operation partner
- Tool connections

	-MFT	-MP	-MOD
Field of application: Supply and exhaust air in the comfort zone and sensor-compatible media	X	X	X
AC/DC 24 V supply	X	X	X
Integrated Δp sensor, dynamic D3, measuring range:	-0.08...2 in WC [-20...500 Pa]	-0.08...2 in WC [-20...500 Pa]	-0.08...2 in WC [-20...500 Pa]
Actuator variants:			
– Rotary actuator	45/90 in-lb [5/10 Nm]	45/90 in-lb [5/10 Nm]	45/90 in-lb [5/10 Nm]
– Linear actuator	–	100/200/300 mm	
VAV function $\dot{V}_{min} \dots \dot{V}_{max}$	X	X	X
CAV stages $\dot{V}_{min} / \dot{V}_{mid} / \dot{V}_{max}$	X	X	–
Open Loop (external V control)	X	X	X
DCV	Yes*	DDC MP Partners*	Yes*
Analog control	0/2...10 V	0/2...10 V	0/2...10 V
With Bus control	–	X	X
Bus specification	–	Belimo MP Bus	Modbus RTU / BACnet MS/TP / RS485
Direct integration DDC MP Partners	–	X	–
Integration via Gateway	–		–
– BACnet		X	
– KNX		X	
– LONWORKS®		X	
– Modbus RTU		X	
Number of bus devices	–	8 per strand	32 per strand
Sensor integration	–		
– passive (resistance)		X	–
– active (0...10 V)		X	X
– Switching contact		X	X
Optional control function	–	–	–
Local forced (override)	–	CLOSED / \dot{V}_{max} / OPEN	CLOSED / \dot{V}_{max} / OPEN
Aids	–	MP-Bus Tester MP Monitor	–
Integration tools	–	PC-Tool	...
TypeList function (Retrofit, OEM)	–	X	(–)
Tool connection (U – PP/MP)	PP	PP/MP	PP
Service socket ZTH / PC-Tool	X	X	X
NFC interface	–	X	–
Assistant App	–	X	–
Service tool ZTH US	X	X	X
PC-Tool	X	X	X
– Parameter			
– Save data			
– Trend, Logbook			
– Label Print			

* Third party controller or control logic within BMS required.